

Robinia story

2300 SERIES – ENCHANTED CASTLE

Model Name: **UL-WS2313**

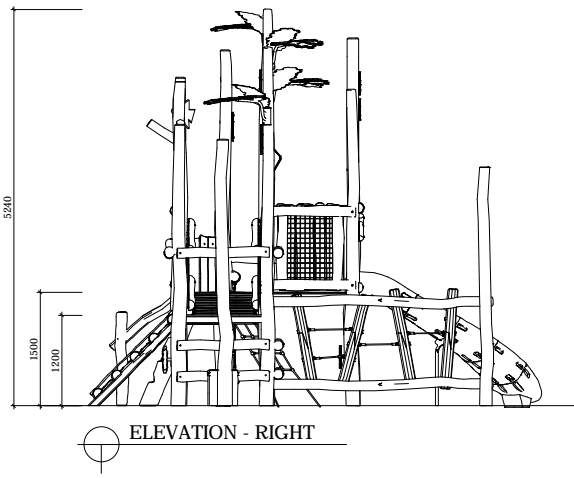

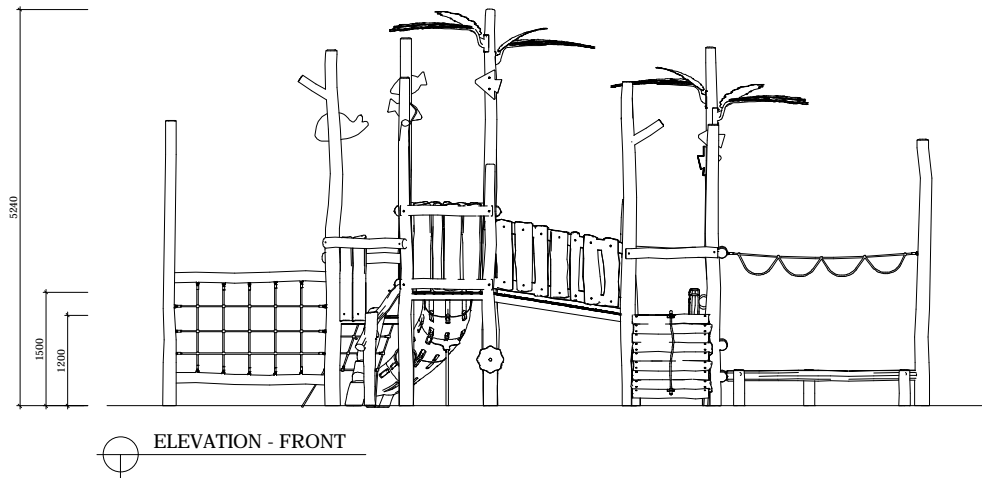
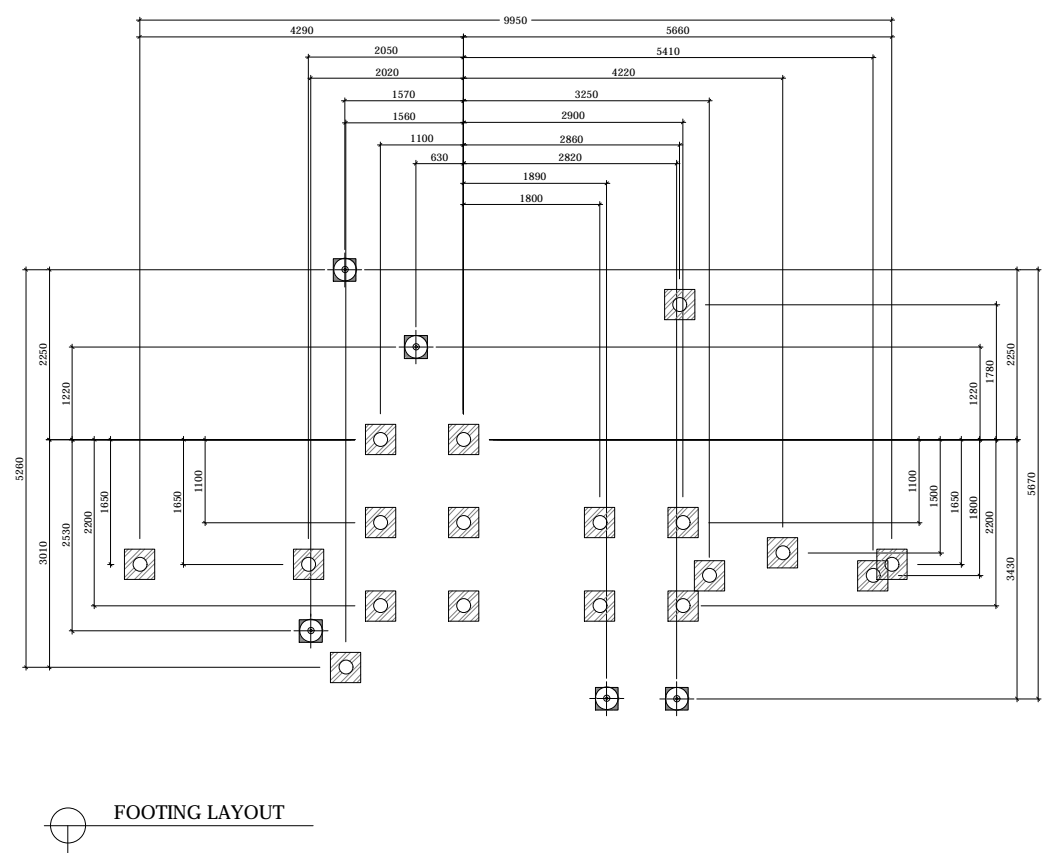
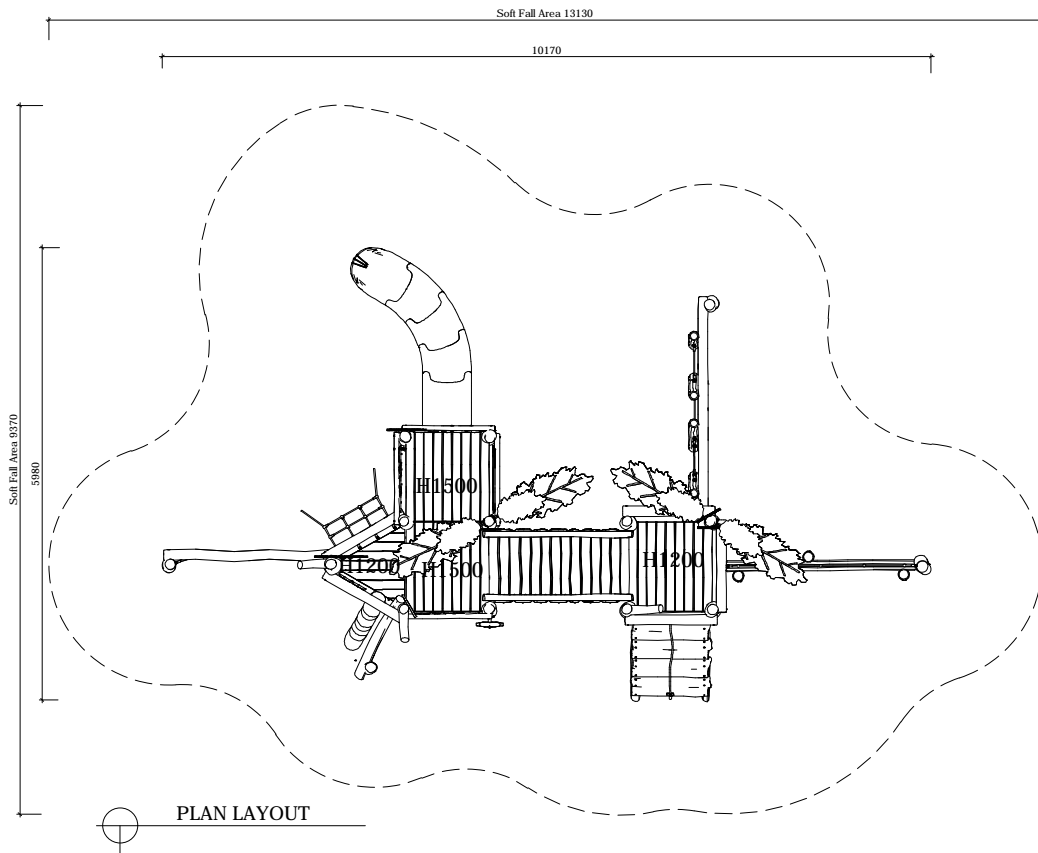

Specification
Product Category : Enchanted Castle
Model Name : UL-WS2313
Standards: AS4685 Parts1-6 & 11 - 2014
Scale: 1:100 @ A4

- Summary:
- Play structure size : 10.2m x 6.0m
 - Approx. soft fall area : 82.1m²
 - Approx. soft fall size : 13.1m x 9.4m
 - Accommodates : 20 to 25 children
 - Overall height : 5.2m
 - Free height of fall : 1.8m



CRS Creative Recreation Solutions PTY LTD
 Address: Unit 1/25 Durgadin Drive Albion Park Rail NSW 2527
 Phone: (02) 4256 2991 Fax: (02) 4256 3991 E-mail: info@crs.net.au Web: www.crs.net.au

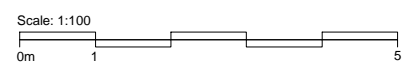

Note:
 • DO NOT mirror, reverse or reflect this design
 • DO NOT scale in any way
 If in doubt ask one of our friendly staff:
 Phone: (02) 4256 2991 E-mail: info@crs.net.au

